



Top Loading Cryostat - Non Optical

Closed Cycle Cryostat

Models:

CS202A-x19	<9K	
CS202A(T)-x19	<9K	Turbo for High Power
CS202N-x19	<6K	
CS202S-x19	<4K	

Applications:

Resistivity, Vibrating Sample Magnetometer (VSM).
 Magnetic Susceptibility.
 Hall Probe Experiments
 Non-Optical,

Standard Features:

- Sample In Vapor.
- Sample temperature will be 1 to 2 K higher.
- VSM adapter available as an option.
- Sample space; 0.7 in (Diameter) * 6.0 in. (long).
- Pneumatic Drive Displex Cryocooler for low vibrations at the sample (see Specifications).
- Vacuum Shroud; All welded stainless steel. No epoxy joints.
- Metallized thermfoil heater for long heater life.
- Two temperature sensors. One mounted on the cryocooler for control and second mounted on sample tube OD. Vacuum side.
- Vacuum valve with NW-25 flange installed.



VSM
Attachment

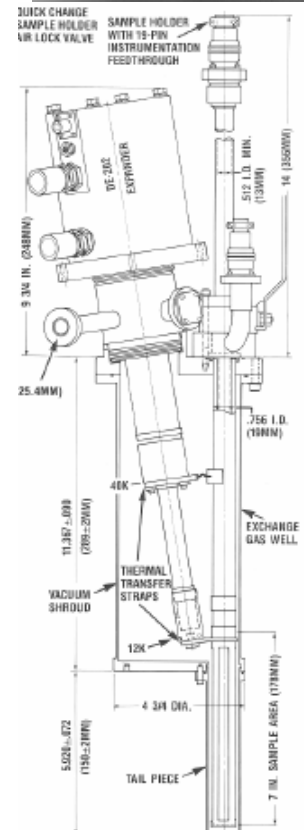

Cryocooler Specifications at 60 Hz.				
Cryo-cooler Model:	CS-202A	CS-202A (T)	CS-202N	CS-202S
Temperature Range	<9K -350K	<9K-350K	<6K - 350K	<4K - 350K
Cooldown Time to 20K	50 Minutes	30 Minutes	60 Minutes	60 Minutes
Cooling Power (2 nd Stage)	0.5 Watts/10K	0.7 Watts/10K	1 Watts/10K	0.12 Watts/4K
	2.5 Watts /20K	2.5 Watts /20K	2.3 Watts /20K	2.3 Watts /20K
Cooling Power (1 st Stage)	10 Watts/70K	Same	Same	Same
Vibrations at sample	+/- 15 Microns	Same	Same	Same
Compressor Model.	ARS-2HW	ARS-4HW	ARS-2HW	ARS-2HW
Compressor Maintenance	12,000 Hrs.			
Ambient, Operating	12 C - 40 C (54 F - 104 F)			
System Weight:	Cryo-cooler - 7 Kg. Compressor - 73 Kg.			
Power Requirements:	208-230V, 60 Hz. 208-220V, 50 Hz. Optional: 230V or 240V, 50 Hz. (With optional transformer)			