

# attoCFM II: Fiber Quality Control - Fluorescence Imaging



The attoCFM II is an ultra compact confocal microscope which is miniaturized for in situ analysis. The microscope is highly stable at low temperature, high magnetic field and high vacuum.

A laser beam is coupled on one arm of a single mode optical fiber coupler. The fiber end of the second arm is placed in a ceramic ferrule, to guarantee an accurate position of the fiber in front of the objective and to minimize the optical aberrations. This single mode fiber illuminates the sample and plays the role of the blocking pinhole aperture when collecting the fluorescent or scattered light from the sample. Moreover, the mechanical parts are highly stable against thermal drift. Finally, the design is optimized to minimize the light losses and to collect the maximum amount of light scattered by the illuminated point of the sample.

In the application shown here, this method is applied to a single mode optical fiber (see pictures on the left). The measurement of the fluorescent light in the core of the optical fiber provides information on the doping elements location and spatial distribution inside the core of the fiber.

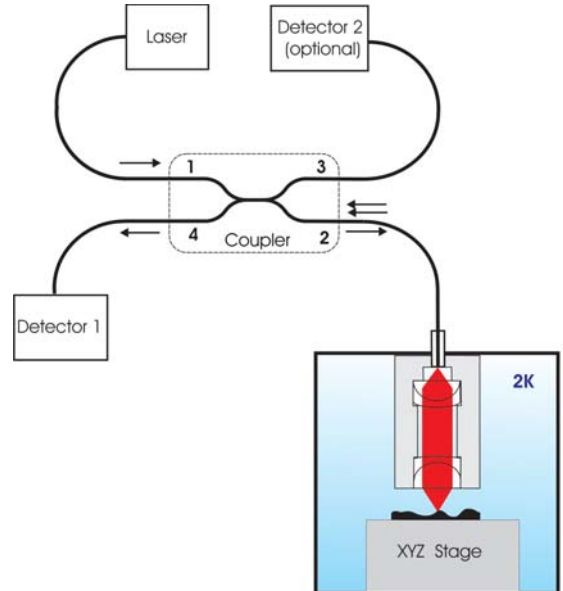

**Fig. 1:** Schematic drawing of the attoCFM II microscope

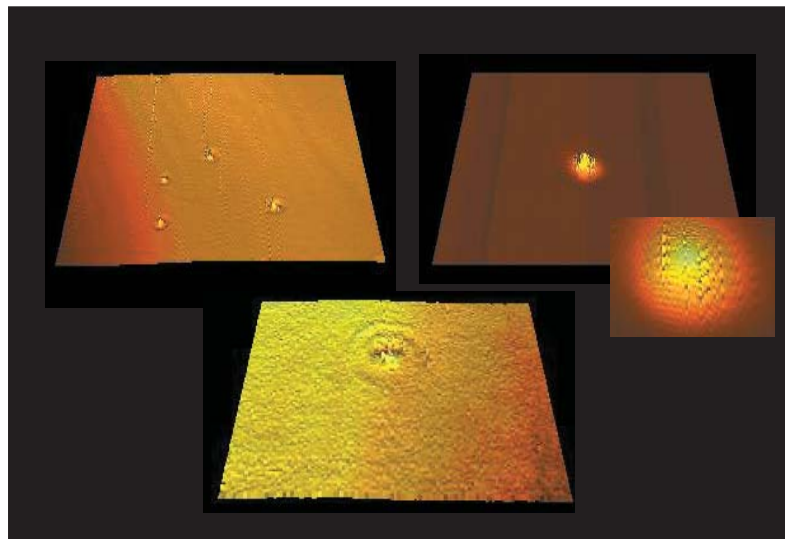

**Fig. 2:** Fluorescence of the core of a single mode fiber measured by the confocal setup. Left above: topography of the cleaved fiber end without any illumination. Right above: the through-the-fiber transmitted light is detected. Below: the distribution of the doping elements in the core of the fiber is clearly resolved.

RELATED PRODUCTS	
attoCFM II	highly stable and compact confocal microscope
ANPxyz100/LT	high precision, piezo electric, inertial positioner for big loads
ANSxy100	high precision piezoelectric scanner
ANC150/3	electronic controller
ANC200	electronic scan controller
attoSCAN	data acquisition software
attoVIEW	data viewing software